

Shock Absorber Instruction Manual

Important: Read these instructions carefully before using the product.

1. Store the manual nearby Store these instructions in a nearby safe place for easy access when a reference is needed.

2. Precautionary statements These statements provide information on a potentially hazardous situation. Always read and fully understand the precautionary statements before starting a procedure.

 **Warning:** Indicates a hazardous situation that, if not avoided, could result in death or serious injury.

 **Caution:** Indicates a hazardous operation or maintenance procedure that, if not avoided, could result in minor or moderate injury.

3. Contents of warnings



■ Do not discard in fire!

- Disposal of the product by discarding in fire could cause personal injury and is a fire hazard.
- Discard oil according to the predetermined waste oil disposal treatment method.

4. Contents of cautions



■ Make sure the installed part delivers maximum strength before operating!

- Operating the mother machine while the part is not fully installed risks damaging the mother machine and may cause personal injury.
- Ensure optimal strength performance of the installed part by the maximum resistance x safety factor. (Refer to the catalog for the maximum resistance.)

■ Make sure the external stopper is installed before operating

- If the product is operated without the external stopper in place, the mother machine may be damaged due to bottoming.
- Be sure to operate the machine after installing the external stopper at the position determined for each model. (Refer to the description on the back to position the external stopper.)

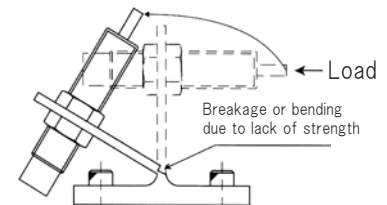

■ Make sure the product is tighten to the correct torque value

- If the product is installed outside the correct tightening torque value, malfunction may occur and the mother machine may be damaged.
- Install the product and tighten to the specified torque value indicated on the back of this sheet.

■ Make sure there is no looseness of the retaining ring

- Using a machine outside its design specifications risks personal injury because abnormally high inner tube pressure can cause the retaining ring to come off and internal parts to come out.
- Never bring your face close to a shock absorber equipped with a retaining ring during machine operation.

■ Concerning disposal of oil

- Disposal of oil sealed in the shock absorber without a reason is a cause of environmental pollution.
- When disposal is necessary, dispose of oil according to the predetermined waste oil disposal treatment method.

■ Concerning dispersion caused by a damaged cap

- Using a shock absorber outside its design specifications risks personal injury due to dispersion.
- Be sure to install the cover to prevent dispersion.

■ Concerning eccentric load and eccentric angle

- A load colliding where the deflection angle is $\pm 2.5^\circ$ risks restoration failure caused by bending of the piston rod, performance degradation caused by eccentric friction on the sliding portion occur, and the mother machine may be damaged. *Regarding MAKCS and MAKSS series, the deflection angle is $\pm 1^\circ$.
- Make certain that the load is at the center line on the piston rod. (If the deflection angle is $\pm 2.5^\circ$ or more, be sure to use a shock absorber with the deflection adapter. The shock absorber can handle a deflection angle up to $\pm 10^\circ$.)

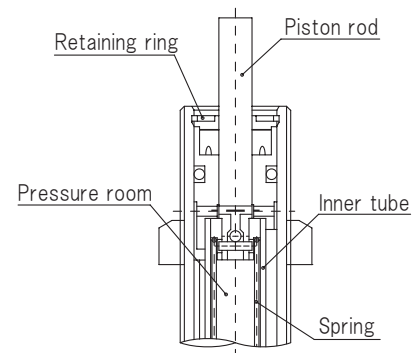

■ Concerning range of operating temperatures

- Always use the shock absorber within the correct range of operating temperatures.
- The influence of the packing and accumulator can diminish the life of the shock absorber and may damage the mother machine. (Refer to the catalog or description on the back for the correct range operating temperatures.)

■ Concerning usage environment

- Do not use the shock absorber in a vacuum or under high pressure to prevent damage to the mother machine.
- Using the shock absorber in an environment where chips, cutting fluids and water can adhere to the piston rod risks operational failure due to oil leakage caused by damaged packing, and may damage the mother machine.

* However, a coolant-resistance type shock absorber can be used in some environments where cutting fluids are applied. (Refer to the catalog for details.)

A coolant-resistance type shock absorber has a special packing configuration and premature leakage of oil may occur if the shock absorber is used in an environment where no fluid is applied on the piston rod. Also, sufficient durability may not be obtained due to the type and amount of fluid used.

We recommend carrying out tests in order to verify the appropriateness of the shock absorber.

MAC, MAS, MAKC, MAKs, MAMS, MAMKS, MACC, MACS, EMACN MAKCS and MAKSS series

5. Contents of description Refer to the catalog for product specifications and dimensions. Please use this product only within the range of specifications.

5-1 Installation method

- When using this product in parallel with two or more lines, use the same model for each line for uniform performance. Because the synchronization of absorbing characteristics differ, do not use an adjustable type shock absorber.
- Do not use the shock absorber as a stopper. Use the shock absorber after installing it 1mm in front of the stroke end.

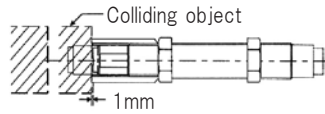

- Tighten the shock absorber mounting to the following torque value.

External diameter of screw (mm)	M4×0.5	M6×0.75	M8×0.75 M8×1	M10×1	M12×1 M12×0.75	M14×1.5 M14×2.0	M16×1.5 M16×2.0	M20×1.5	M25×1.5 M25×2.0	M27×1.5 M27×3.0	M30×1.5	M36×1.5	M42×1.5
Nut tightening torque (N/m)	0.35	0.85	3.9	7.8	7.8 ※1	9.8	14.7	29.4	49	58.8	78.4	98	392

* Using a bonding agent for locking is recommended.

*1 Tightening torque of EMACN series is 1.5N·m.

However, when securing the nut to make the product contact the portion of $\phi 14.6$, tighten the nut to a torque value of 1N·m.

5-2 How to adjust the adjustable shock absorber

- For the shock absorber equipped with an analog adjustment scale, set the adjustment control at the middle between 1 and 2 and inspect the situation of collision. Then, readjust and set the scale to the optimal position. (Characteristics are weak.) 1<--2->3 (Characteristics are strong.) (Characteristics are weak) 1<-->7 (Characteristics are strong.)

Note) Be sure to protect the shock absorber with an external stopper or stopper nut during adjustment.

When finished adjustment, then tighten a locking screw.

If the shock absorber is used unlocked, the adjustment control will slip, preventing the proper level of shock absorption.

Note that there are models that are not equipped with a locking screw. (Refer to the following section.)

When using a model without a locking screw, the adjustment shaft does not rotate. The adjustment shaft may rotate, however, if it is used at the position where vibration occurs. Determine whether to use the model after carefully checking the actual machine.

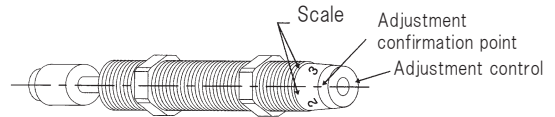

○ MAC, MAS, MACC, MACS 0806/1008/1210 series that are not equipped with the locking screw mechanism

5-3 Usage environment

- Be sure to use the product where ambient temperature ranges from -5°C to $+70^{\circ}\text{C}$. * For EMACN, the ambient temperature range is from -10°C to $+50^{\circ}\text{C}$.
- The product storage temperature ranges from -10°C to $+80^{\circ}\text{C}$. * For EMACN, the ambient temperature ranges from -20°C to $+50^{\circ}\text{C}$.
- Use the shock absorber in an atmospheric pressure environment.
- Use of the shock absorber location where ozone is present, may shorten its service life.
- Use the shock absorber under conditions where humidity ranges from 0 to 80% (No condensation.)

5-4 Product body

- Handle the product with care to prevent damage to the piston rod. A damaged piston rod degrades durability and may lead to restoration failure.
- Be sure not to damage the seal. A damaged seal will lead to a oil leakage and may degrade durability.
- Be careful not to damage the spring of a shock absorber equipped with an external spring. A damaged spring will damage the piston rod, degrade durability, and lead to restoration failure.
- Do not turn the screw at the oil inlet on the bottom of the shock absorber to prevent oil leakage.
- Product durability varies depending on conditions of use.
- Do not lubricate the piston rod. Lubricating the piston rod may cause oil leakage and degrade durability.

5-5 Maintenance

- The shock absorber is not designed to be maintained through repeated disassembly and reassembly procedures. Note) When it is necessary to disassemble the shock absorber, do not stand in front of the shock absorber during the disassembly because the spring-loaded piston rod can fly out and cause personal injury!

5-6 Product Selection

- Refer to "● Selection procedure" in the catalog "Oil type shock absorber - Outline -" for selecting a shock absorber.

Optional parts The following optional parts are available. Select optional parts after referring to the catalog.

- Stopper nut - Deflection angle adapter

Note) Optional parts are not available for all models. Please note that there might be no corresponding optional parts for the product you are considering.

Always take measures to prevent a secondary harmful event when working with a shock absorber.

URL <http://jp.misumi-ec.com/mech/>